

AIR CHAIN HOIST

TCR-250C

WLL	Lifting speed with load	Lifting speed without load	Lowering speed with load	Air consumption lifting	Air consumption lowering	Air connection
250 kg	9,3 m/min	19 m/min	17,9 m/min	11,7 l/sec	15 l/sec	3/8" BSPT

Minimum hose diam.	Chain falls	Chain size mm	Working pressure	Weight with 3m hol	Additional meter hol	-
1/2" hose	1	4 x 12 RTS	6 bar	7 kg	0,35 kg	-

Information subject to change without notice

DIMENSIONS IN MM

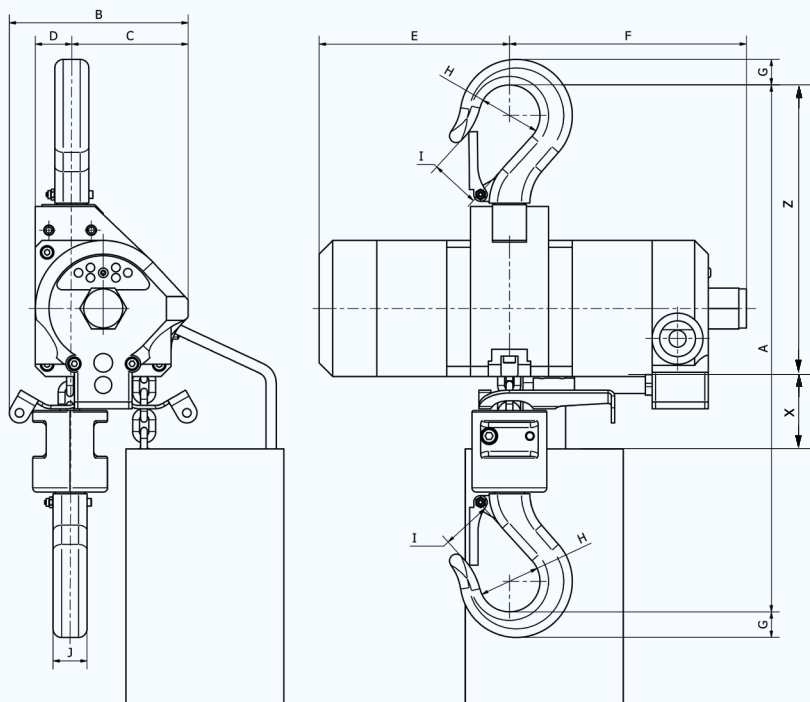

A	B	C	D	E	F	G	HØ	I	J	X	Z
305	105	69	22	112	140	15	35	22	20	40	170

All measurements are in mm / Information subject to change without notice

